

Building of fiber optic networks in an urban environment FTTx



SIDECUT SC4P

A performant microtrencher for the deployment of fiber optic networks in urban environment

Process

- Axially driven cutting wheel
- Microtrench for fiber optic network

Specific features

- Limited size of the vehicle, which allows cutting in sidewalks
- Dry microtrenching
- Sound proofing of the components
- No blasting and no dust during the burying works
- Quick network deployment process

Innovation

- Fully remote controlled
- Radio with LCD display showing working parameters (remotely available via Re.M portal):
 - Trenching hours (total/partial)
 - Trenching distance (total/partial)
 - Trenching depth
 - Machine operating parameters (pressure & temperature)
 - Faults/anomalies

Assets

- The microtrench and the job site are clean
- Speed of execution
- No disturbance to pedestrians during the works
- Limited disturbance to residents
- Increased safety of the jobsite
- No damage to road foundations
- Sidewalk can be used again very soon
- Reduction in building costs
- Trenching in curves

Output

- Between 40 and 120 m/hour



Features of the cutting tool

- Axially driven cutting wheel

Type of wheel	Cutting width (mm)	Trench depth (mm)
R350	35 to 70	up to 350

- Cutting tool mounted on 5-axis boom
- Slope correction of the tool $\pm 15^\circ$

Sizes and weight

- Length in working position: 4.55 m
- Width: 1.05 m
- Height: 1.93 m
- Weight: ca. 3 t

Carrier

- Articulated carrier with 4 wheel drive
- 74 ch (54.5 kW) Tier 4 stage 3B diesel engine
- Hydrostatic translation

Accessories

- Remote control

Technical diagram

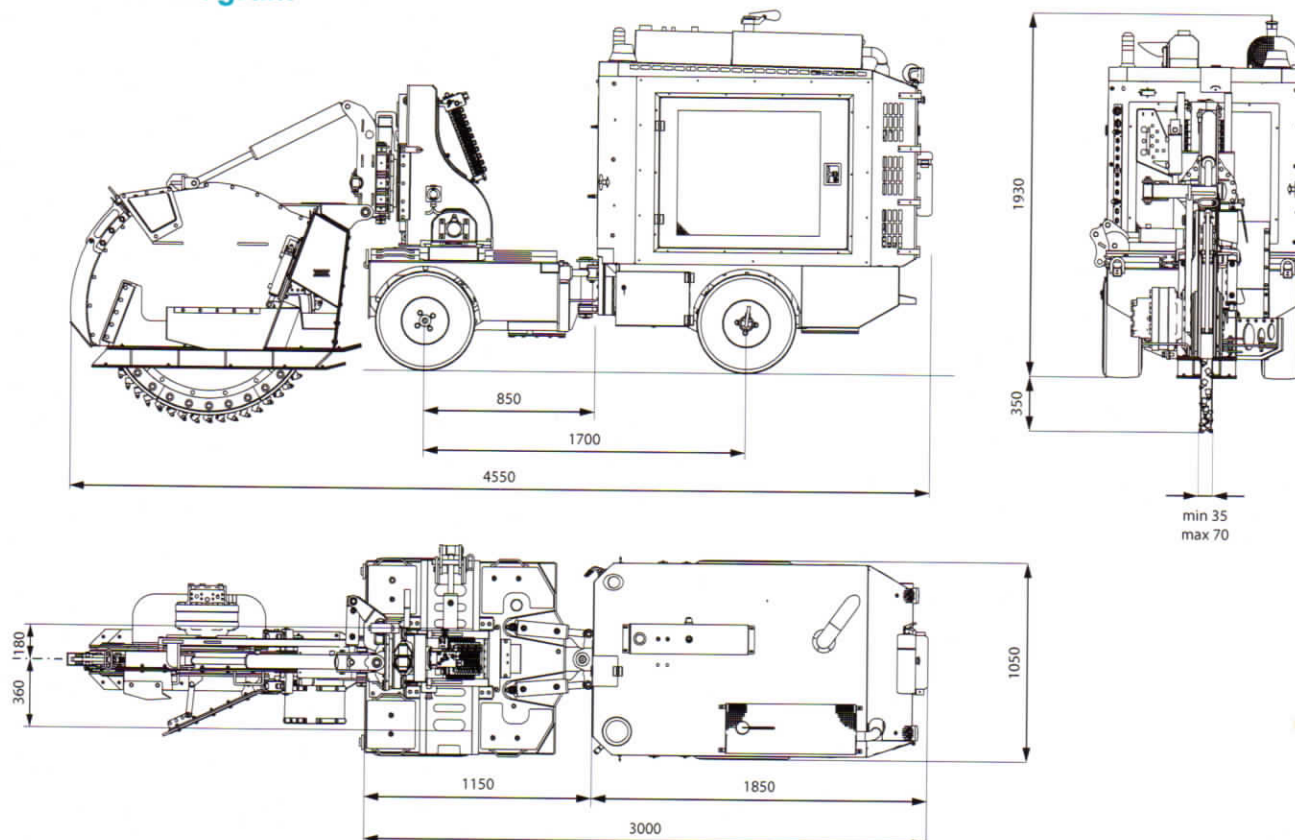

MARAIS

TESMEC GROUP COMPANY

www.samarais.com

ZA Les Portes de l'Anjou
 1, rue Pierre et Marie CURIE BP 20 - 49430 DURTAL (France)
 Tel. : +33 (0)2 41 96 16 90 / Fax : +33 (0)2 41 96 16 99
 e-mail : info@samarais.com