

SIDECUT SC3C

Building of fiber optic networks in urban environment FTTX



MARAIS

GROUPE

A reference for micro-trenching

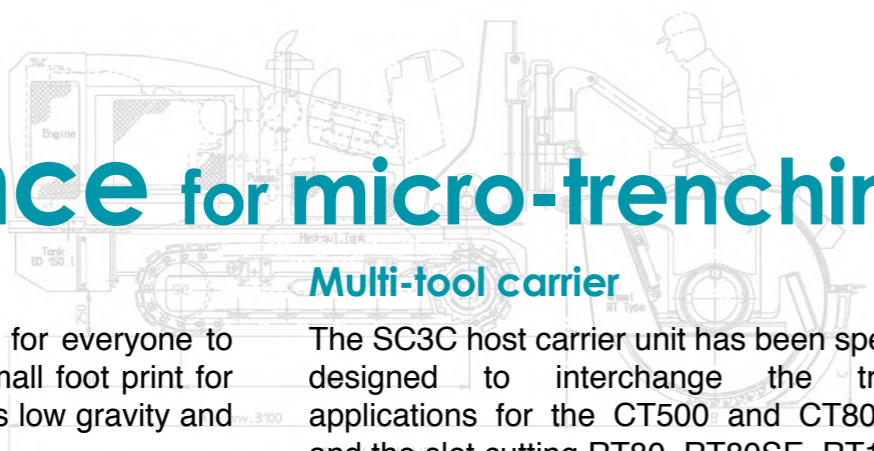

All purpose trencher

The SC3C has been designed for everyone to appreciate its versatility and small foot print for slit trench applications due to its low gravity and narrow undercarriage

- With the radio control as standard, the operator is free to move to the safest place keeping an optimal view of the site ;
- The two independently controlled tracks offer great stability combined with a full and precise maneuverability ;
- The ground clearance is sufficient to negotiate a footway curb without associated plant or equipment.

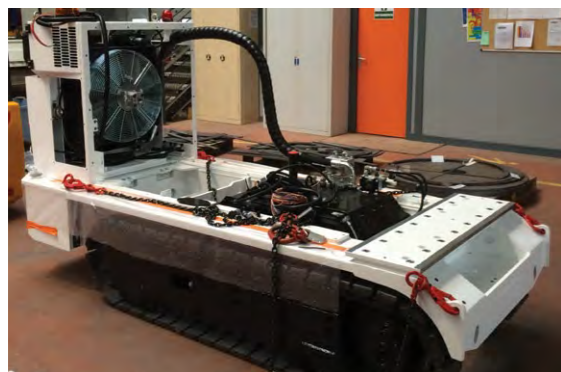

Optimized ground pressure

The SideCut SC3C is available in two undercarriage widths with a rubber pad facility to suit the clients projects with no damage to original job site surfaces :

- These rubber track pads available at 200mm wide for the 1100 unit ;
- or 300mm wide for the 1300 unit with an increase of 50% in lift.

In both cases, the trencher has a low center of gravity and optimum balance, which ensures stability and perfect grip at work or transfer.

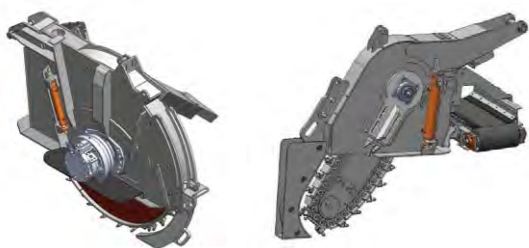

Multi-tool carrier

The SC3C host carrier unit has been specifically designed to interchange the trenching applications for the CT500 and CT800 chain and the slot cutting RT80, RT80SE, RT100, and RT125 without further modifications.

- Positioning the tool is easy thanks to the 5 variations of movement from the remote operator system ;
- Trenching radius curves are precise and simple due to the +/- 30 degree clearance of the pivot tool in open or locked down modes ;
- The $\pm 15^\circ$ tool tilt allows positioning the wheel regardless the ground slopes ;
- The large lateral displacement of the tool can be supplemented by optional extension slide, allowing a 250 mm offset to the right (axis trench to track edge).

Multiple motorization

The 100 hp Deutz diesel engines are available in design formations of 3A, 3B or 4 and are built to the EU emission regulations ;

- The engine speed set to 2000 rpm, guarantee best performance (power, torque) with reduced fuel consumption and noise ;
- The single radiator for water, inter-cooler and oil is suitable for work in hot countries.



Simplified maintenance

Coolers are combined within a single radiator, hydraulics are grouped to the main pump system, replacement parts and filters for the SC3C are designed for easy access to simplify daily maintenance duties :

- Large side door giving access to the engine components ;
- Grouping of hydraulic and electrical components in an easily removable cover.



More flexibility to fit your needs

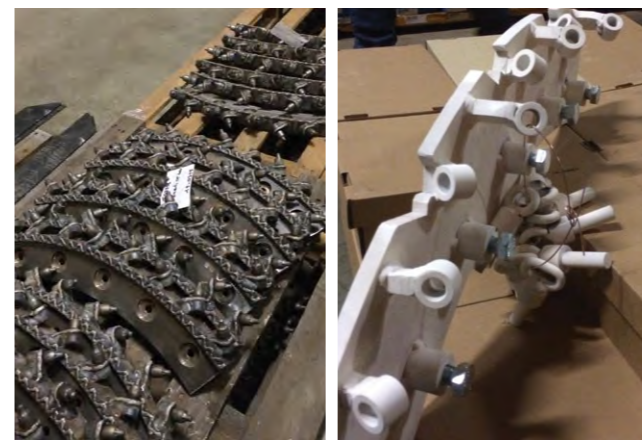

Marais in house manufacture offer several cutting tools making for easy interchange for the project requirement and specification.

Its unique tools for both chain and wheels are equipped with the Marais cutting segments which are specifically designed to suit all variable ground conditions, maximizing production with low maintenance costs.



Groupe Marais is there to support you with your projects, providing your operators a theoretical and practical training on your jobsite ; customer can thus control micro-trencher driving and maintenance safely and with self-confidence.

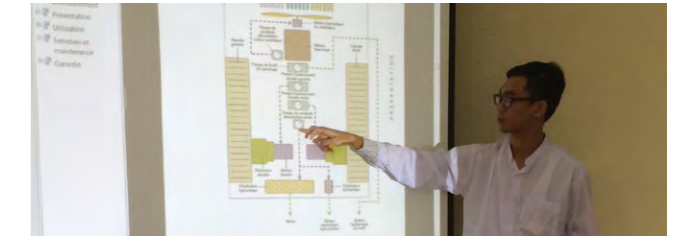

With a Worldwide partnership network, MARAIS offers a quality service with the support of local knowledgeable partners and an international back up support team. Full proposal and package requirement options can be provided for individual client needs : from your delivery date on site through to customer support and service, MARAIS customers can feel confident and secure with all their specialist project requirements.



A large range of possibilities

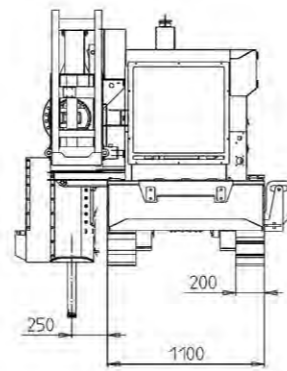
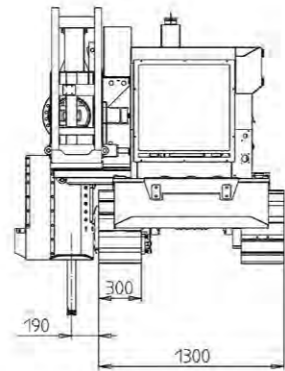
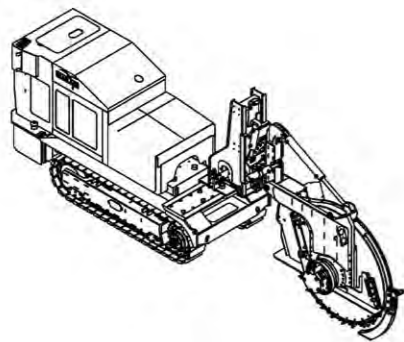
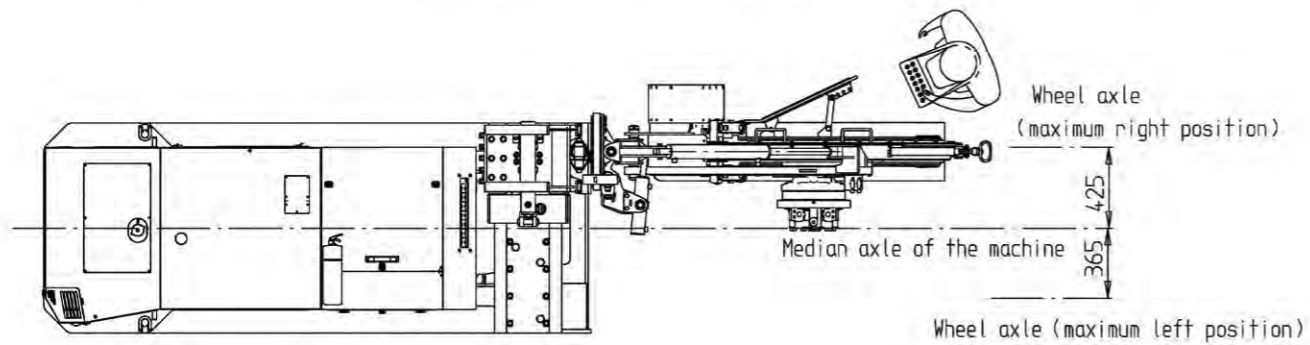
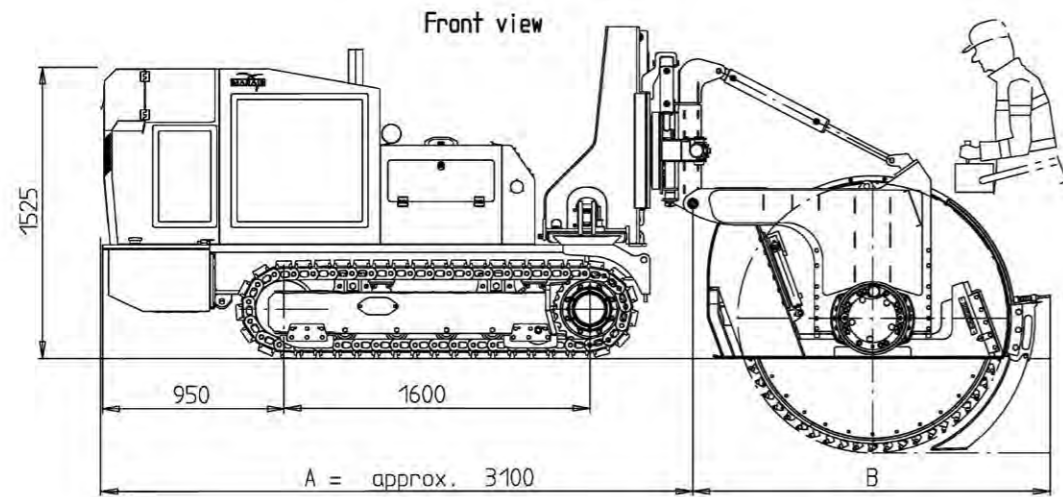

Chain / Wheel	Depth (mm)*		Width (mm)*		Equipment length (mm)*	
	Min	Max	Min	Max	Length B	Length A+B
CT 800	540	800	80	120	1590	4690
CT 550	300	550	80	120	1440	4540
RT 125	250	450	45	80	2000	5100
RT 100	250	350	45	60	1700	4800
RT 80	100	250	45	60	1400	4500
RT 80 SE	100	250		35	1400	4500
RT 80 SEE	100	250		25	1400	4500

* Other width and depth on request

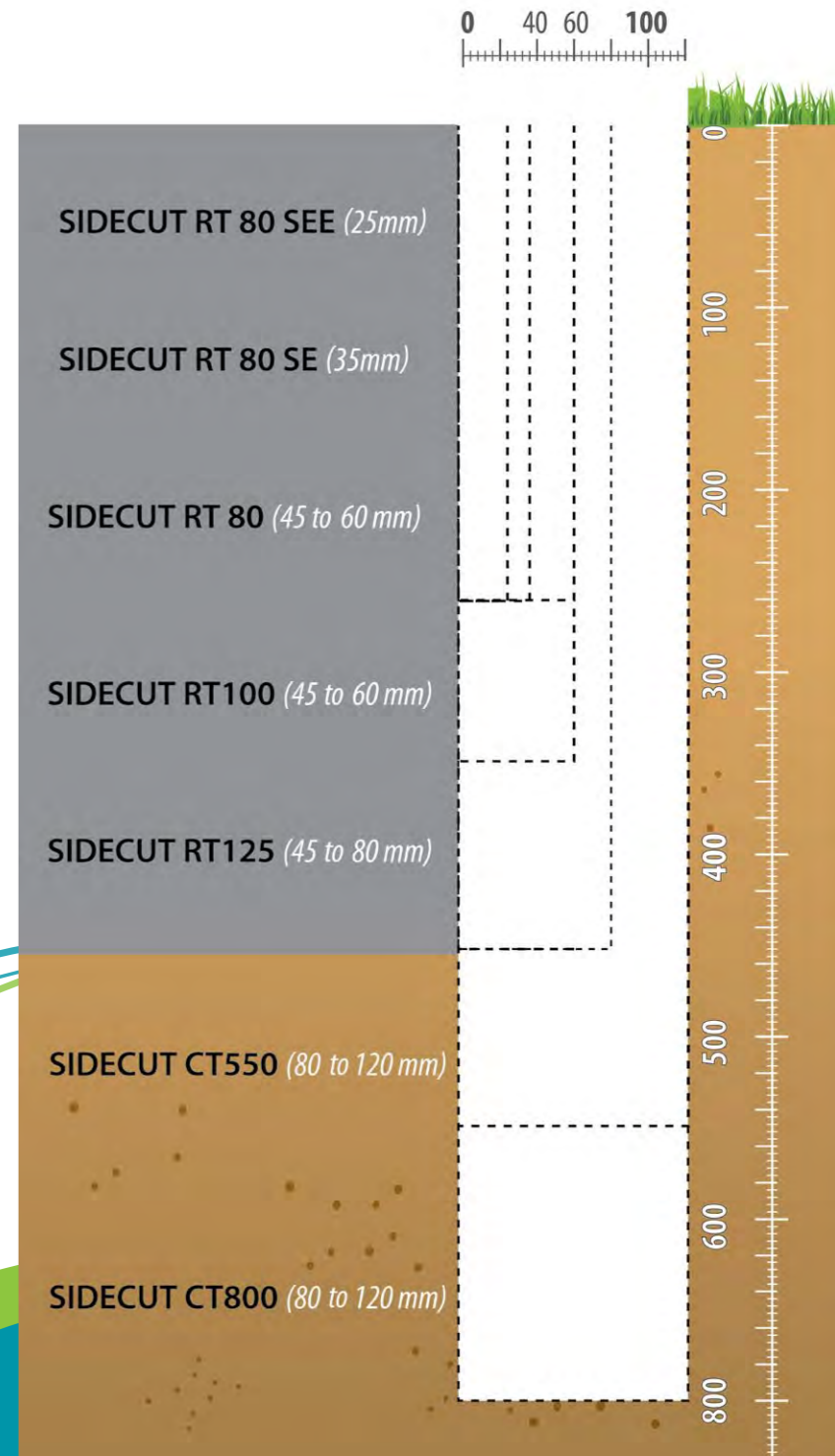
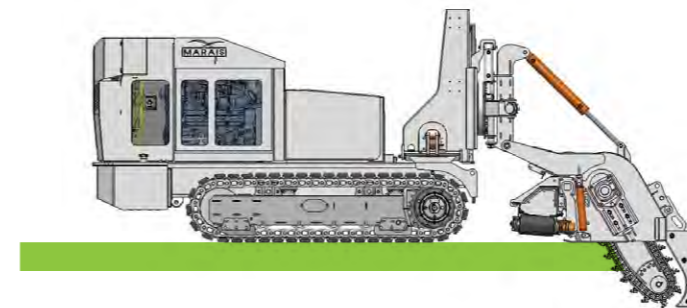

A large range of trenchers to answer your needs



ZA Les Portes de l'Anjou
1, rue Pierre et Marie CURIE BP 20 - 49430 DURTAL (France)
Tél. : 33 (0)2 41 96 16 90 / Fax : 33 (0)2 41 96 16 99
e-mail : info@samarais.com