

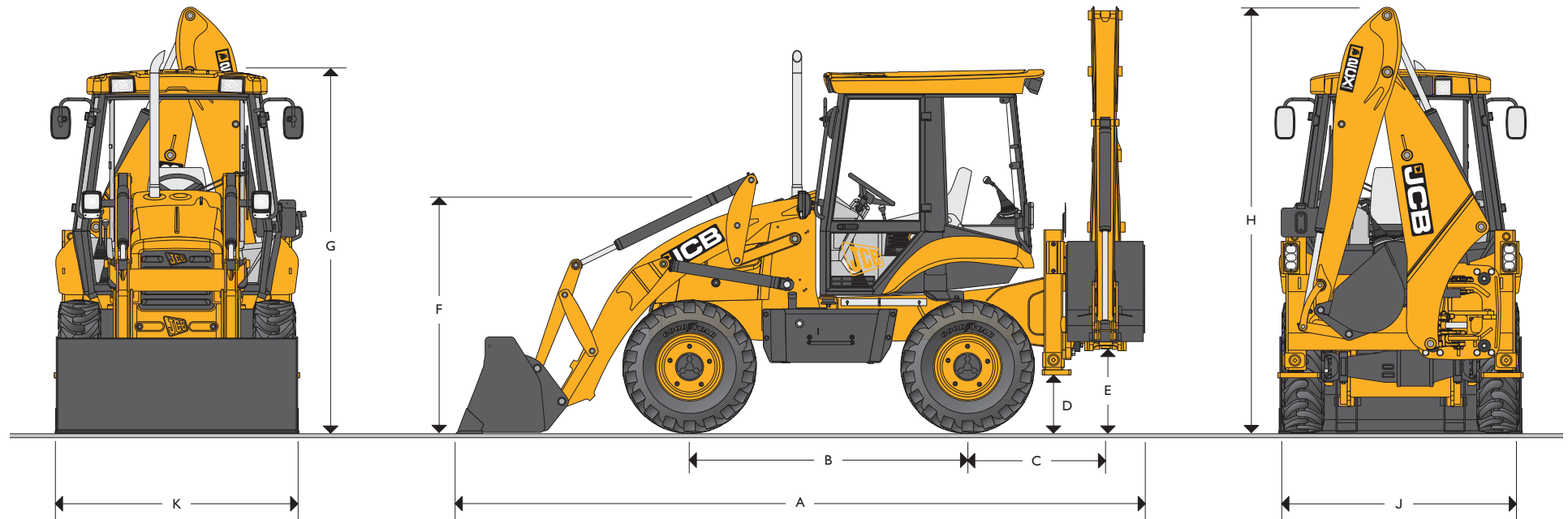

MAX. ENGINE POWER: 55kW (75hp) MAX. BACKHOE DIG DEPTH (STANDARD DIPPER): 3.67 metres (12ft 0in)



STATIC DIMENSIONS

JCB Backhoe Loaders feature heavy-duty one piece mainframe, componentised driveline and fully enclosed engine compartment. All fluid and component compartments are lockable using the ignition key.

Machine model	2CX	2CX Streetmaster	2CX S
	m (ft-in)	m (ft-in)	m (ft-in)
A Total travel length	5.13 (16-10)	5.40 (17-9)	5.13 (16-10)
B Axle centreline distance	1.99 (6-6)	1.99 (6-6)	1.99 (6-0)
C Slew centre to rear axle centre distance	1.13 (3-8)	1.13 (3-8)	1.13 (3-8)
D Stabiliser feet clearance	0.31 (1-0)	0.31 (1-0)	0.31 (1-0)
E Kingpost clearance	0.49 (1-7)	0.49 (1-7)	0.49 (1-7)

Machine model	2CX	2CX Streetmaster	2CX S
	m (ft-in)	m (ft-in)	m (ft-in)
F Steering wheel centre height	1.76 (5-9)	1.76 (5-9)	1.76 (5-9)
G Cab roof height	2.65 (8-8)	2.65 (8-8)	2.65 (8-8)
H Total travel clearance	2.72 (8-11)	2.72 (8-11)	3.05 (10-0)
J Rear frame width	1.85 (6-1)	1.85 (6-1)	1.98 (6-6)
K Shovel width	1.85 (6-1)	1.85 (6-1)	2.00 (6-7)



MAX. ENGINE POWER: 53.8kW (73hp)

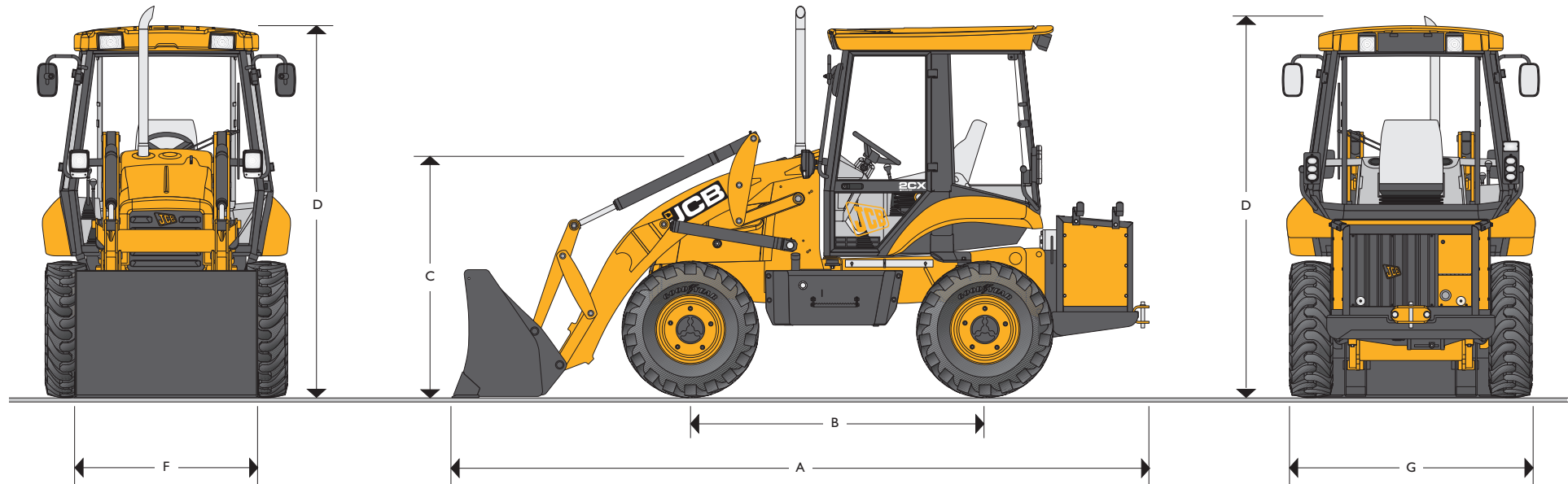

STATIC DIMENSIONS

JCB 2CX Airmaster Loaders feature heavy-duty one piece mainframe, componentised driveline and fully enclosed engine compartment. All fluid and component compartments are lockable using the ignition key.

Machine model	2CX Airmaster
	m (ft-in)
A Total travel length	5.17 (16-11)
B Axle centreline distance	1.99 (6-6)
C Steering wheel centre height	1.76 (5-9)
D Cab roof height	2.65 (8-8)

Machine model	2CX Airmaster
	m (ft-in)
E Total travel clearance	2.72 (8-11)
F Shovel width (blacktop GP shovel)	1.37 (4-6)
G Width over tyres	1.83 (6-0)



GROUND LINE ANGLES

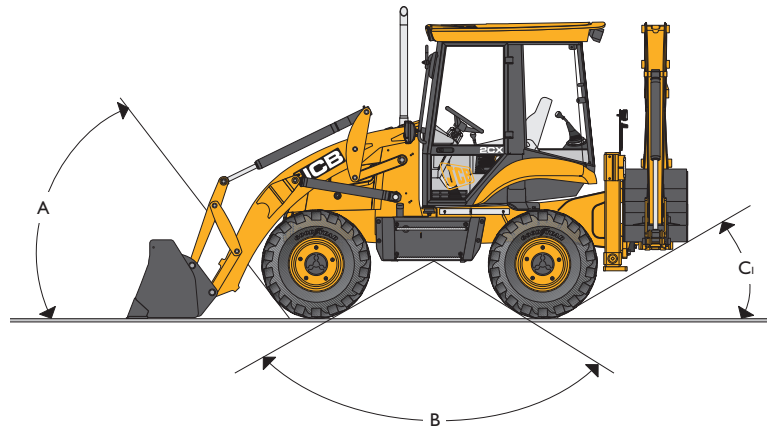

- A Approach angle 45°
- B Interference angle/ramp to ground plane 130°
- C1 Departure angle 27°
- C2 Departure angle 27°

OPERATING WEIGHTS

Machine model	2CX	2CX Streetmaster	2CXS	2CX Airmaster
	kg (lb)	kg (lb)	kg (lb)	kg (lb)
Weight	5900 (12980)	6300 (13860)	6150 (13530)	5890 (12958)

ENGINE

Direct injection diesel. Belt driven water pump, cold start aid – territory dependent.

Machine model	2CX 2CX Streetmaster 2CXS	2CX Airmaster
Engine emissions	Stage III	Stage III
Manufacturer	JCB	JCB
Aspiration	Turbo charged	Turbo charged
Displacement	litre 4.4	4.4
No. of cylinders	4	4
Bore	mm 103	103
Stroke	mm 132	132
Rated engine rpm	2200	1900
Power ratings		
Rated ISO 14396 (SAE J1995 Gross)	kW (HP) 55 (75)	53.8 (73)
Maximum torque		
Rated ISO 14396 (SAE J1995 Gross)	Nm (lbf ft) 329 (243)	329 (243)
Max. torque rpm	1200	1200

STEERING

Full power hydrostatic system utilising the main hydraulic pump with integral steering priority valve. In the event of engine failure, emergency steering is maintained.

Machine model	2CX	2CX Streetmaster	2CXS	2CX Airmaster
Steering axles	Front and rear	Front and rear	Front and rear	Front and rear
Steering turns – lock to lock	4	4	4	4
	m (ft-in)	m (ft-in)	m (ft-in)	m (ft-in)
Kerb – kerb turning circle – unbraked – 4WS	6.85 (22-6)	6.85 (22-6)	7.20 (23-9)	6.85 (22-6)
Kerb – kerb loader clearance circle – unbraked – 4WS (2000mm GP)	8.71 (28-7)	8.71 (28-7)	9.35 (30-8)	8.71 (28-7)

ENGINE SUPPORT SYSTEM

Engine support system is designed for ease of daily checks, routine maintenance and longer service intervals.

Fuel type	Diesel.
Fuel filter	Replaceable spin-on cartridge plus water/sediment separator.
Air cleaner	Dual, dry element cyclonic type.
Oil filter and lubrication	Full flow, spin-on type filter.
Cooling system	Hot climate specification, pressurised 14.5 psi (1.0 bar) suction fan. Pressurised recovery tank.



ELECTRICAL AND INSTRUMENTATION

12 volt negative ground, utilising wiring and connectors meeting IP69 water ingress test standard. Central fuse panel supplemented with main circuit breakers at battery positive terminal.

Gauges	Tachometer, engine coolant temp, fuel level, hourmeter clock.
Warning system	Audible and visual system for engine oil, transmission, park brake, battery, air cleaner, alternator.
Battery	900 CCA/110 A/hr.
Pre-wire	Radio speakers (cab), beacon (all).
Horn	Controlled from both front and rear.
Alternator	95 amp.
Front working lights	2 twin beam fixed position.
Rear working lights	2 adjustable.

TRANSMISSION

The JCB Transmissions are designed and built specifically for JCB Backhoe Loaders. They feature synchronised shifting in all gears. Powershuttle between forward and reverse. Ground speeds are designed to maximise production.

Machine model	2CX	2CX Streetmaster	2CXS	2CX AM Airmaster
Manufacturer	JCB	JCB	JCB	JCB
Type	Syncroshuttle	Syncroshuttle	Syncroshuttle	Syncroshuttle
Torque converter	280mm (11")	280mm (11")	280mm (11")	280mm (11")
Torque converter ratio	2.67:1	2.67:1	2.67:1	2.67:1
Gears forward/reverse	4	4	4	4
Gear selection	Manual	Manual	Manual	Manual
Shuttle control – F/R	Power shuttle	Power shuttle	Power shuttle	Power shuttle
Travel speeds	kph (mph)	kph (mph)	kph (mph)	kph (mph)
Tyres – front 12.5x18				
Gear 1	3.6 (2.2)	3.6 (2.2)	3.6 (2.2)	3.3 (2.1)
Gear 2	9.9 (6.2)	9.9 (6.2)	9.9 (6.2)	8.9 (5.5)
Gear 3	20.5 (12.7)	20.5 (12.7)	20.5 (12.7)	18.1 (11.2)
Gear 4	33.1 (20.6)	33.1 (20.6)	33.1 (20.6)	28.8 (17.9)

FRONT AXLE

JCB front axles are designed and built specifically for backhoe loaders and accept a wide variety of tyre combinations.

Machine model	All models
Type	JCB Max-trac steer drive torque proportioning
Axle ratings	kg (lb)
Static load rating	7484 (16500)
Dynamic load rating	3765 (8300)
Oscillation angle	9.5°
Steering ram	Double acting

REAR AXLE

JCB rear axles are designed and built specifically for backhoe loaders and accept a wide variety of tyre combinations.

Machine model	All models
Type	JCB Max-trac torque proportioning with outboard planetary drive
Limited slip	
Axle ratings	kg (lb)
Static load rating	7484 (16500)
Dynamic load rating	3765 (8300)

CAB

- Excellent visibility (and safety) is provided by the extra large tinted glass areas. Cab frame is ROPS and FOPS approved for maximum operator protection. ISO standard 3471 and 3449 (SAE J11040 and J231).
- A fully adjustable seat with lumbar support combines with ergonomically positioned controls to minimise operator fatigue.
- The in-cab noise levels are the lowest in the business for maximum operator comfort.
- A radio location is provided as standard plus twin speakers for stereo sound.
- Cab provides easy access through a left hand single door. Standard features include: lap seat belt, 3 speed fresh air/recycle heater, front and rear screen wash/wipers (cab), front and rear horn, exterior mirrors, and flat easy-clean floor.
- The instrument panel is positioned to the right-hand side for ease of viewing from either the loading or excavating position and has an optional lockable cover for vandal proofing. Engine speed, fuel and coolant temperature gauges, (and clock on cab builds) are mounted in the panel.
- Fixed steer column.
- Large opening rear window (cab).
- Static or mechanical suspension seat gives the operator a comfortable operating position.
- 12V power supply.

BRAKES

The JCB braking system ensures effective, fade-free braking. The self-adjusting, multi-disc arrangement is inboard mounted and is oil immersed for minimum maintenance and a long operating life.

- Twin brake pedals provide tighter turning circle and enhanced steering control on slippery ground.
- Automatic compensation ensures 'straight' machine braking.
- Disc diameter: 165 mm (6.5 in). Friction area: 130502 sq.mm (202 sq. in) per brake.
- The independent parking brake is mounted on the input shaft rear axle and will hold the machine on 1:3 gradients. It is an over-centre type, adjustable within the cab, with transmission disconnect to prevent premature brake pad wear. Park brake disc diameter: 285 mm (11.2 in). Friction area: 74984 sq.mm (116 sq. in).



TYRES

- 340/65 x R18 Goodyear
- 340/80 x R18 Michelin XMCL
- 12.5 x 18 x 10 Goodyear
- 340/80 R18 Goodyear IT530

HYDRAULIC SYSTEM

The Open Centre system uses gear pumps with a power modulation valve that automatically varies hydraulic power to match digging conditions for extra performance and power.

- Open centre hydraulic system using simple and reliable high efficiency gear pump.
- Single pump system with priority valve to ensure metered supply to steering and main hydraulic system.
- Easily used, ergonomically positioned levers give excellent control of the loader and backhoe, thus reducing operator fatigue.
- A full flow 10 micron filter ensures that oil stays free of contaminants.

Machine model	2CX, 2CXs, 2CX Airmaster** 2CX Streetmaster
Pump flows at 2200rpm*	l/min (gal/min)
Main pump output	81.0 (17.8)
System working pressure	bar (lbf/sq in)
Backhoe and loader	230 (3335)

*Optimum flow

**1900rpm

SERVICE CAPACITIES

Machine model	2CX, 2CX Streetmaster, 2CXs, 2CX Airmaster
	ltr (gal)
Cooling system	14 (3.70)
Fuel tank	83 (18)
Engine oil with filter	11 (2.42)
Transmission with filter	17 (3.74)
Rear axle	9.0 (2.0)
Front drive axle	9.0 (2.0)
Hydraulic system incl. tank	83 (18)

COMPRESSOR (Airmaster model only)

- The screw type compressor is purpose-designed for resurfacing work. It offers true 140 cubic feet per minute (66 litres per second) capacity. A heavy duty cage protect against impact damage while an automatic speed setting on the compressor ensures maximum economy by providing power on demand.
- An external stop/start facility means that the operator doesn't have to be in the cab to engage the compressor drive. It also allows fast shutdown in an emergency.
- With the oil/air receiver only requiring an inspection every 6 years, maintenance time will be cut to a minimum.
- The compressor will only operate when the parking brake is applied. And to minimise the risk of mechanical damage, overheat sensors will disengage the compressor drive if the oil temperature rises above normal.

Type	Compair Holman screw type
Air output	140CFM, 66 litres/sec
Pressure at outlet taps	7 bar (100psi)
Engine speed control	Fully modulating engine speed control linked to air demand
Compressor drive	Direct
Compressor cooling	Air blast type
Air outlets	2¾ locks
Compressor oil capacity	17 litres (3.3 gal)
Ground clearance under compressor assembly	273mm (10.7 in)
Weight of compressor plus balance weight	900kg (1983 lb)
Tool stowage	Two heavy duty breakers
Power take off	Independent, hydraulically operated

SPECIFICATION

Machine model	2CX	2CX Streetmaster	2CXs	2CX Airmaster
Extending dipper	○	●	○	–
Exavator quickhitch	○	●	○	–
Loader quickhitch	○	●	○	○
Hammer pipework	○	●	○	–
Streetpads	○	●	○	–
Toolbox and tools	●	●	●	●
Battery isolator	●	●	●	●
Smooth ride system (SRS)	○	○	○	○
Loader arm pipework	○	○	○	○
Return to dig	○	○	○	○
Object handling kit	○	○	○	–
LiveLink	○	○	○	○
Biodegradeable oil	○	○	○	○
Air conditioning	○	○	○	○
Hydraulic tool circuit	○	○	○	–
Hydraulic hose reel (9m)	○	○	○	–

● = Standard, ○ = Option



LOADER DIMENSIONS

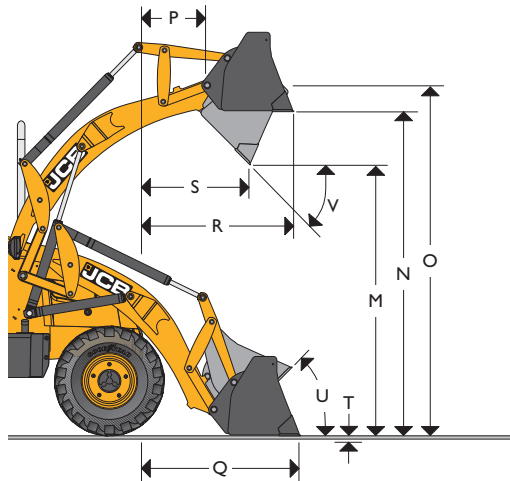

LOADER

JCB loaders provide parallel lift self levelling on the up and down cycle enhancing load retention and use of optional pallet forks. High capacity buckets combined with high lift and breakout forces maximise productivity.

		G.P. Shovel	6 in 1
Bucket breakout force	kgf (lbf)	3600 (7921)	3600 (7921)
Loader arm breakout force	kgf (lbf)	3850 (8471)	3850 (8471)
Lift capacity to full height (1850mm wide)	kg (lb)	2200 (4844)	2100 (4624)

LOADER DIMENSIONS

	Narrow bucket	GP shovel	6 in 1 shovel
	m (ft-in)	m (ft-in)	m (ft-in)
Overall width with bucket	1.37 (4-6)	2.00 (6-7)	2.00 (6-7)
M Dump height	2.42 (7-11)	2.49 (8-2)*	2.48 (8-2)*
N Load over height	2.99 (9-10)	2.99 (9-10)	2.99 (9-10)
O Loader hinge pin height	3.24 (10-8)	3.24 (10-8)	3.24 (10-8)
P Pin forward reach	0.33 (1-1)	0.33 (1-1)	0.33 (1-1)
Q Reach at ground (toe plate horizontal)	1.43 (4-8)	1.43 (4-8)	1.44 (4-9)
R Max. reach at full height	1.13 (3-9)	1.13 (3-9)	1.14 (3-9)
S Reach at full height fully dumped	0.71 (2-4)	0.71 (2-4)	0.71 (2-4)
T Dig depth	0.10 (0-4)	0.10 (0-4)	0.10 (0-4)
U Roll back at ground	degrees 45°	45°	45°
V Dump angle	degrees 45°	45°	45°
Jaw opening width	N/A	N/A	0.70 (2-3)
Available on			
2CX		●	●
2CXS		●	●
2CX Streammaster			●
2CX Airmaster	●	●	●



LOADER ATTACHMENTS

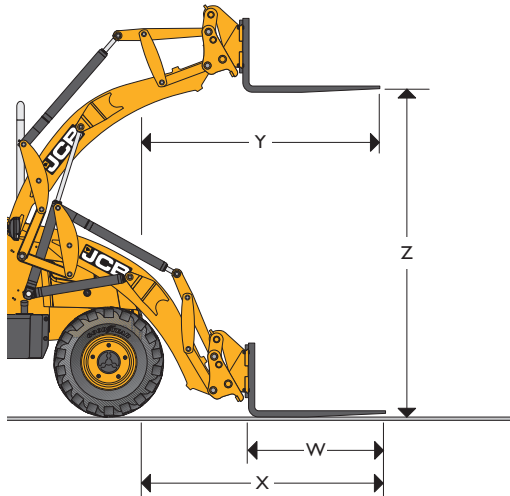

LOADER DIMENSIONS – Forklift Performance Data

		Quickhitch mounted forks
		m (ft-in)
W	Forks – tine length	1.20 (3-11)
	Forks – tine width	0.1 (0-4)
X	Forks reach at ground level	1.02 (3-4)
Y	Forks reach at full height	0.71 (2-4)
Z	Forks lift height – max.	3.04 (9-11)
	Fork spacing – min	0.15 (0-6)
	Fork spacing – max	1.28 (4-2)
	SWL @ 500mm load centres	kg (lb) 1600 (3526)
	Max. rollback at ground	degrees 10°

LOADER ATTACHMENTS – Direct Mount

Loader buckets are listed according to size and application. All buckets are drilled to accept optional auxiliary cutting edge or teeth. Flat top box section provides rigidity and assists in bucket levelling.

	2CXS			
	G.P. Shovel Capacity SAE		6 in I Shovel Capacity SAE	
Width mm (ft-in)	Rated m ³ (yd ³)	Struck	Rated m ³ (yd ³)	Struck
2000 (6-7)	0.7 (0.92)	0.56 (0.73)	0.6 (0.78)	0.49 (0.64)
2CX, 2CX Streetmaster, 2CX Airmaster				
		G.P. Shovel Capacity SAE	6 in I Shovel Capacity SAE	
Width mm (ft-in)	Rated m ³ (yd ³)	Struck	Rated m ³ (yd ³)	Struck
1850 (6-0)	0.6 (0.7)	0.46 (0.59)	0.6 (0.78)	0.49 (0.64)

BACKHOE ATTACHMENTS – Standard Profile Bucket

JCB backhoe buckets are designed specifically for use on JCB machines with pin positions to maximize tearout, load retention and straight wall digging characteristics.

Width mm (in)	Capacity SAE	
	m ³ (ft ³)	m ³ (ft ³)
230 (9)	0.028 (1.0)	0.022 (0.79)
300 (12)	0.03 (1.07)	0.03 (1.07)
350 (14)	0.04 (1.43)	0.03 (1.07)
400 (16)	0.05 (1.79)	0.04 (1.43)
450 (18)	0.06 (2.14)	0.05 (1.79)
600 (24)	0.09 (3.21)	0.07 (2.50)
750 (30)	0.11 (3.93)	0.09 (3.21)

BACKHOE ATTACHMENTS – Grading Bucket

Width	Capacity Rated
mm (in)	m ³ (ft ³)
1200 (48)	0.16 (5.71)

BACKHOE ATTACHMENTS – Hammermaster 260L Rockbreaker

Required oil flow	20 – 68 ltrs per minute
Strike rate	300 – 1675 blows per minute
Tool diameter	63mm
Joules per blow	350
Working weight	230kg (506lb)

BACKHOE DIMENSIONS – 2CX & 2CX Streetmaster

		2CX	2CX, 2CX Streetmaster
		Standard Dipper	Extradig
		m (ft-in)	m (ft-in)
A	SAE max dig depth	Ext 3045 (10-0)	3701 (12-2)
		Ret –	3053 (10-0)
	SAE 2ft flat bottom	Ext 3020 (9-11)	3675 (12-1)
		Ret –	3026 (9-11)
B	Reach – ground level to rear wheel centre	Ext 5114 (16-9)	5727 (18-9)
		Ret –	5107 (16-9)
C	Reach – ground level to slew centre	Ext 3987 (13-1)	4600 (15-1)
		Ret –	3980 (13-1)
D	Reach – at full height to slew centre	Ext 1406 (4-7)	1897 (6-3)
		Ret –	1406 (4-7)
E	Side reach – to centre line of machine	Ext 4428 (14-6)	5045 (16-7)
		Ret –	4432 (14-6)
F	SAE operating height	Ext 4073 (13-4)	4454 (14-7)
		Ret –	4028 (13-3)
G	Maximum loadover height	Ext 2772 (9-1)	3235 (10-7)
		Ret –	2809 (9-3)
H	Total kingpost travel	Ext 894 (2-11)	894 (2-11)
		Ret –	894 (2-11)
J	Bucket rotation	187°	187°

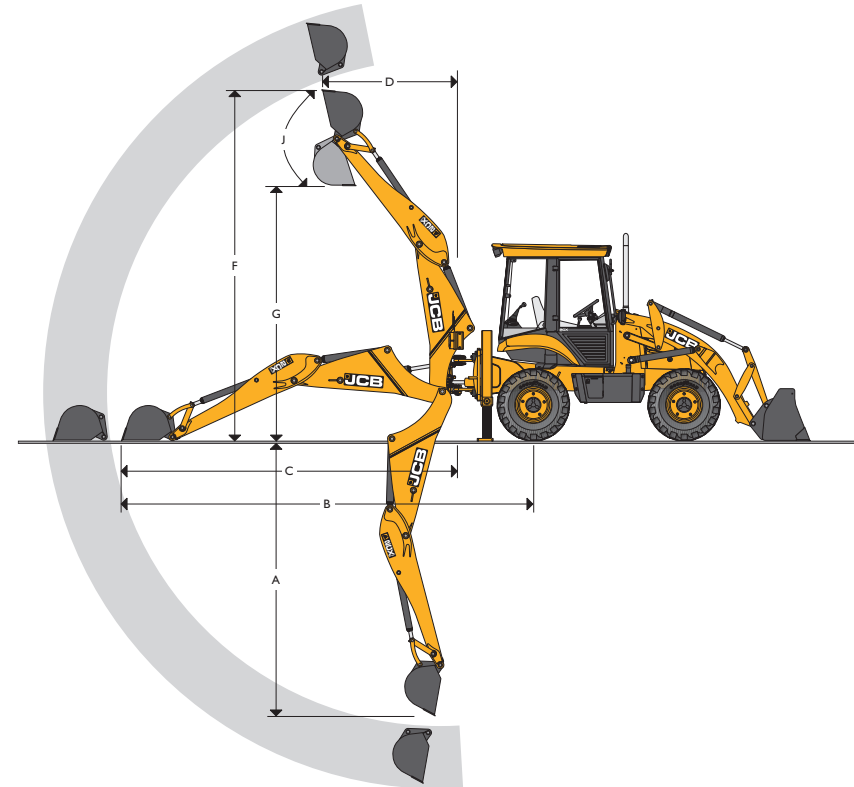

BACKHOE DIMENSIONS – 2CX & 2CX Streetmaster

		2CX	2CX, 2CX Streetmaster
		Standard Fixed Dipper	Extradig
		kgf (lbf)	kgf (lbf)
	Bucket tearout	4200 (9259)	4200 (9259)
Dipper tearout	Ext	–	1733 (3821)
	Ret	2253 (4967)	2284 (5035)
		kg (lb)	kg (lb)
Lift capacity of bucket pivot at full reach	Ext	–	729 (1607)
	Ret	980 (2161)	821 (1810)

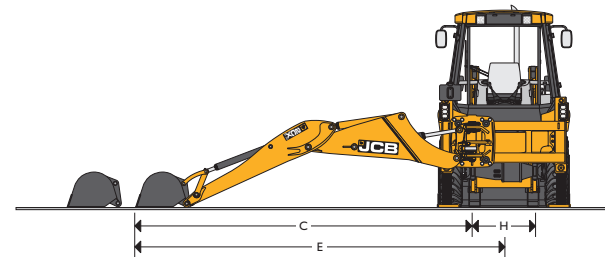

BACKHOE DIMENSIONS – 2CX5

		Standard Dipper	Extradig
		m (ft-in)	m (ft-in)
A	SAE max dig depth	Ext 3.66 (12-0)	4.31 (14-2)
		Ret –	3.66 (12-0)
	SAE 2ft flat bottom	Ext 3.59 (11-8)	4.24 (13-11)
		Ret –	3.59 (11-8)
B	Reach – ground level to rear wheel centre	Ext 5.74 (18-10)	6.35 (20-10)
		Ret –	5.73 (18-10)
C	Reach – ground level to slew centre	Ext 4.61 (15-2)	5.22 (17-2)
		Ret –	4.60 (15-1)
D	Reach – at full height to slew centre	Ext 2.67 (8-9)	3.16 (10-4)
		Ret –	2.67 (8-9)
E	Side reach – to centre line of machine	Ext 5.15 (16-11)	5.73 (18-10)
		Ret –	5.13 (16-10)
F	SAE operating height	Ext 4.59 (15-0)	4.97 (16-4)
		Ret –	4.59 (15-0)
G	Maximum loadover height	Ext 3.32 (10-11)	3.74 (12-3)
		Ret –	3.32 (10-11)
	SAE loadover height	Ext 3.29 (10-10)	3.70 (12-2)
		Ret –	3.28 (10-9)
H	Total kingpost travel	1.02 (3-4)	1.02 (3-4)
J	Bucket rotation	187°	187°

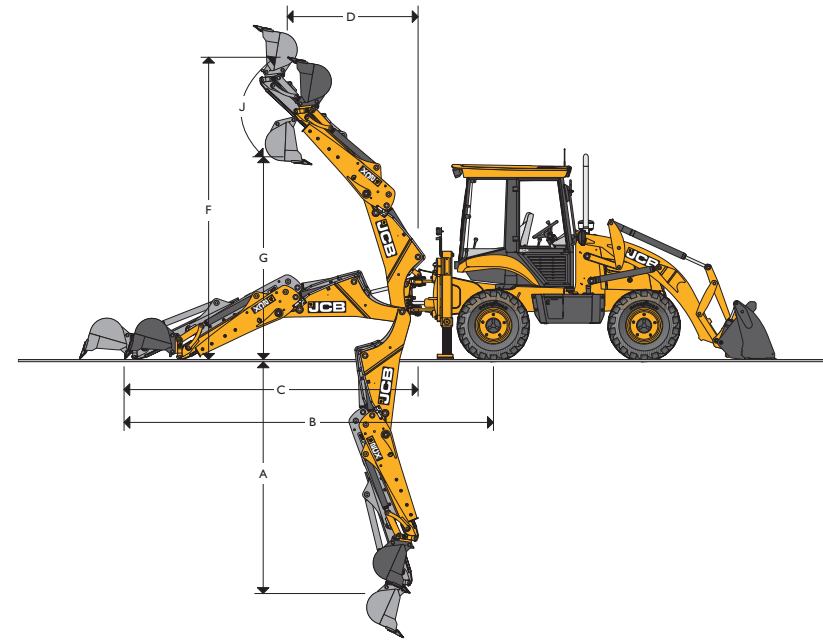

BACKHOE PERFORMANCE – 2CX5

		Standard Dipper	Extradig
		kgf (lbf)	kgf (lbf)
Bucket tearout		4200 (9259)	4200 (9259)
Dipper tearout	Ext	2487 (5483)	1970 (4343)
	Ret	–	2487 (5483)
		kg (lb)	kg (lb)
Lift capacity of bucket pivot at full reach	Ext	747 (1646)	453 (998)
	Ret	–	697 (1536)

