

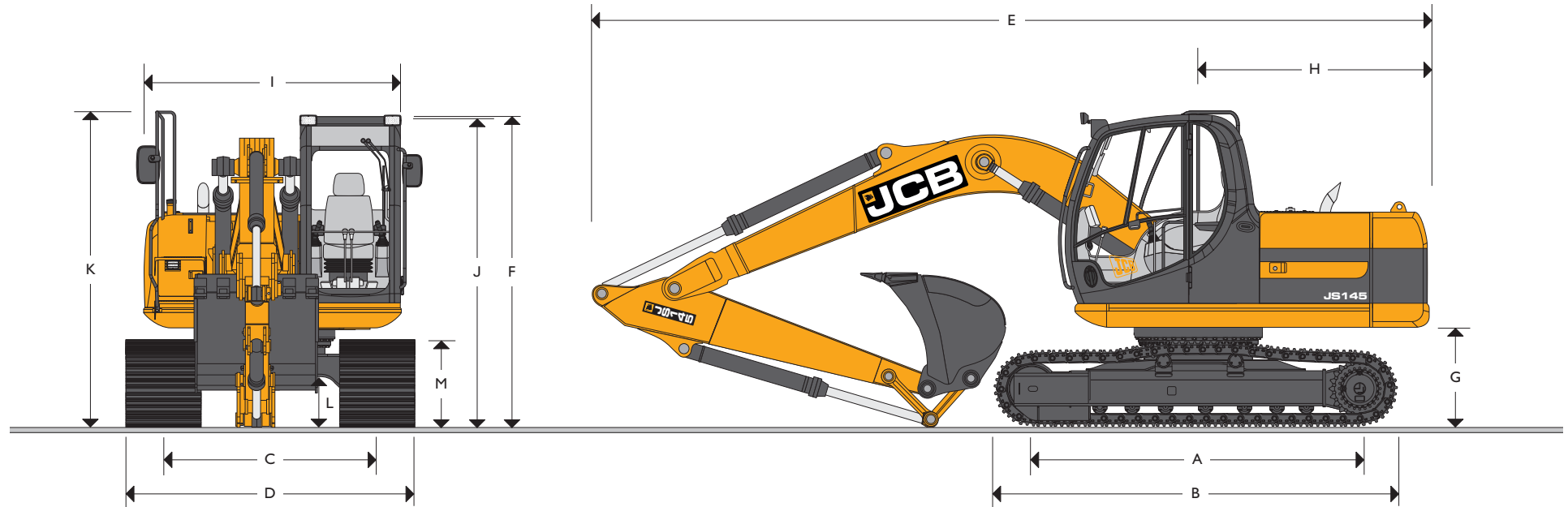

MAX. OPERATING WEIGHT: 15200 kg (33510 lb) MAX. ENGINE POWER: 73 kW (98 hp)



STATIC DIMENSIONS – JS145LC MONOBOOM

Dimensions in millimetres (ft-in)		
A	Track length on ground	2865 (9-5)
B	Undercarriage overall length	3605 (11-10)
C	Track gauge	1990 (6-6)
D	Width over tracks (500mm trackshoes)	2490 (8-2)
D	Width over tracks (600mm trackshoes)	2590 (8-6)
D	Width over tracks (700mm trackshoes)	2690 (8-10)
D	Width over tracks (850mm trackshoes)	2840 (9-4)
<b>Dipper lengths</b>		<b>2.5m (8ft 2in)      3.0m* (9ft 10in)</b>
E	Transport length with Monoboom	7620 (25-0)      7572 (24-10)
F	Transport height with Monoboom	2867 (9-5)      3289 (10-9)

Dimensions in millimetres (ft-in)		
G	Counterweight clearance	905 (3-0)
H	Tail swing radius	2050 (6-9)
I	Width of superstructure	2410 (7-11)
J	Height over cab	2845 (9-4)
K	Height over grab rail	2867 (9-5)
L	Ground clearance	425 (1-5)
M	Track height	811 (2-8)

\*Machine in transport position



MAX. OPERATING WEIGHT: 15200 kg (33510 lb) MAX. ENGINE POWER: 73 kW (98 hp)

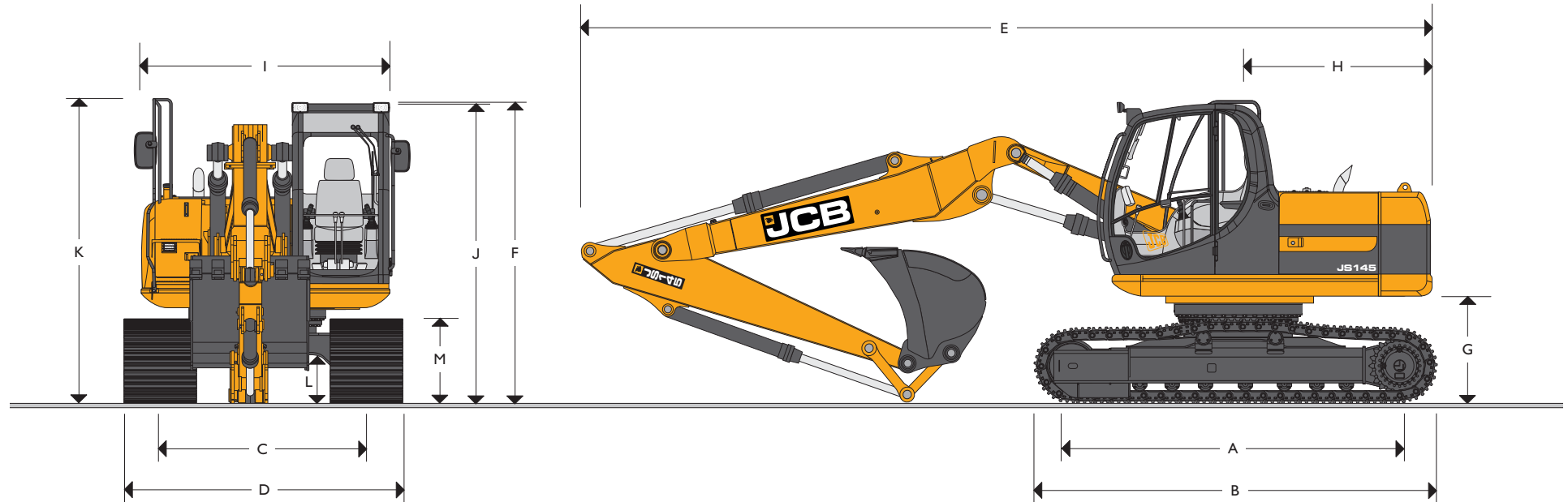

STATIC DIMENSIONS – JS145LC T.A.B.

Dimensions in millimetres (ft-in)		
A	Track length on ground	2865 (9-5)
B	Undercarriage overall length	3605 (11-10)
C	Track gauge	1990 (6-6)
D	Width over tracks (500mm trackshoes)	2490 (8-2)
D	Width over tracks (600mm trackshoes)	2590 (8-6)
D	Width over tracks (700mm trackshoes)	2690 (8-10)
D	Width over tracks (850mm trackshoes)	2840 (9-4)
<b>Dipper lengths</b>		
	<b>2.5m (8ft 2in)</b>	<b>3.0m* (9ft 10in)</b>
E	Transport length with T.A.B.	7662 (25-2) 7629 (25-0)
F	Transport height with T.A.B.	2867 (9-5) 3186 (10-5)

Dimensions in millimetres (ft-in)		
G	Counterweight clearance	905 (3-0)
H	Tail swing radius	2050 (6-9)
I	Width of superstructure	2410 (7-11)
J	Height over cab	2845 (9-4)
K	Height over grab rail	2867 (9-5)
L	Ground clearance	425 (1-5)
M	Track height	811 (2-8)

\*Machine in transport position



## ENGINE

<b>Model</b>	Isuzu 4JJ1X EU Stage IIIA, EPA Tier III compliant.
<b>Type</b>	Water cooled, 4-stroke, 4-cylinder in-line, common rail direct injection, turbocharged intercooled diesel.
<b>Rated power (ISO 14899 (SAE J1995))</b>	73kW (98hp) at 2000rpm.
<b>Piston Displacement</b>	2.999 litres (0.67 UK gal).
<b>Injection</b>	Electronic injection.
<b>Air Filtration</b>	Dry element with secondary safety element and in cab warning indicator.
<b>Cooling</b>	Large capacity radiator.
<b>Starting system</b>	24 volt – 4.5kW.
<b>Batteries</b>	2 x 12 volt Heavy Duty.
<b>Alternator</b>	24 volt 50 amp.
<b>Refuelling pump</b>	Electric type.

## SWING SYSTEM

<b>Swing motor</b>	Axial piston type.
<b>Swing brake</b>	Hydraulic braking plus automatic spring applied disc type parking brake.
<b>Final drive</b>	Planetary reduction.
<b>Swing speed</b>	12.8 rpm.
<b>Swing gear</b>	Large diameter, internally toothed fully sealed grease bath lubricated.
<b>Swing lock</b>	Multi position switchable brake.

## UNDERCARRIAGE

<b>Construction</b>	Fully welded, "X" frame type with central bellyguarding and sloping sidemembers with dirt relief holes under top rollers.
<b>Recovery point</b>	Front and rear.
<b>Upper &amp; lower rollers</b>	Heat treated, sealed and lubricated.
<b>Track adjustment</b>	Grease cylinder type.
<b>Track type</b>	Sealed and lubricated.
<b>Track idler</b>	Sealed and lubricated, with spring cushioned recoil.
<b>Track shoes</b>	500mm (20in.) triple grouser 600mm (24in.) triple grouser 700mm (28in.) triple grouser 850mm (33in.) triple grouser
<b>Rollers and Shoes (each side)</b>	Upper rollers 2 Lower rollers 7 Track shoes 44

## HYDRAULIC SYSTEM

A variable flow load sensing system with flow on demand, variable power output and servo operated, multi-function open centre control. Machine auto warm up standard – maximises performance in cold conditions.

**Pumps**

Main pumps	2 variable displacement axial piston type.
Maximum flow	2 x 124 L/min (2 x 27 UK GPM).
Servo pump	Gear type.
Maximum flow	21 L/min (4.6 UK GPM).

**Control valve**

A combined four and five spool control valve with auxiliary service spool as standard. When required twin pump flow is combined to boom, dipper and bucket services for greater speed and efficiency.

**Relief valve settings**

Boom/Arm/Bucket	318 bar (4610lb/sq.in)
With power boost	343 bar (4975lb/sq.in)
Swing circuit	279 bar (4045lb/sq.in)
Travel circuit	343 bar (4975lb/sq.in)
Pilot control	40 bar (569lb/sq.in)

A separate Cushion Control valve in the servo system provides cushioning of the boom and dipper spools selection and quick warm-up of the servo system.

**Hydraulic cylinders**

Double acting type, with bolt-up end caps and hardened steel bearing bushes. End cushioning is fitted as standard on boom, dipper and bucket rams.

Optional hose burst check valves available for boom and dipper rams.

**Filtration**

The hydraulic components are protected by the highest standard of filtration to ensure long hydraulic fluid and component life.

<b>In tank</b>	150 micron, suction strainer.
<b>Main return line</b>	10 micron, fibreform element.
<b>Plexus Bypass line</b>	1.5 micron, paper element.
<b>Pilot line</b>	10 micron, paper element.
<b>Hydraulic hammer return</b>	10 micron, reinforced microform element.

**Cooling**

Worldwide cooling is provided as part of a single face cooling pack, in conjunction with the engine water cooler.

## TRACK DRIVE

<b>Type</b>	Fully hydrostatic, three speed with autoshift between high and medium speed.
<b>Travel motors</b>	Variable swash axial piston type, fully guarded within undercarriage frame.
<b>Final drive</b>	Planetary reduction, bolt-on sprockets.
<b>Service brake</b>	Hydraulic counter balance valve to prevent overspeeding on gradients.
<b>Park brake</b>	Disc type, spring applied, automatic hydraulic release.
<b>Gradeability</b>	70% (35 deg) continuous.
<b>Travel speed</b>	High – 4.9 km/h (3.05 mph). Mid – 2.9 km/h (1.80 mph). Low – 2.3 km/h (1.43 mph).
<b>Tractive effort</b>	128kN (28800lb).



### EXCAVATOR END – MONOBOOM

Monoboom available along with a choice of dipper lengths to suit the requirements of reach, dig-depth, loadover height, tearouts and site versatility. Reserve strength is built into the fully welded structures for hydraulic hammer and other arduous operations. Fabricated bucket tipping links are provided with a choice of lift points. Strong, durable construction, large cross sections and multi plate fabrications to withstand high stress applications. The 4.7m (15ft 5in) boom is designed to ensure the optimum digging envelope when matched with the three dipper lengths. Low maintenance bronze alloy bushes with graphite plugs are fitted to boom base and boom to dipper pivots resulting in 1000 hour greasing intervals at these points.

### EXCAVATOR END – T.A.B.

Triple Articulated Boom (T.A.B.) with a choice of dipper lengths to suit the requirements of reach, dig-depth, loadover height, tearouts and site versatility. Reserve strength is built into the fully welded structures for hydraulic hammer and other arduous operations. Fabricated bucket tipping links are provided with a choice of lift points.

### CAB

Excellent digging, loading and positioning visibility results from the careful design of front, side and roof lights. All screens are tinted to improve in cab conditions. Fully opening front screen is very smooth to operate and as the lower screen is stored within the top screen frame it makes complete front screen opening easy, fast and convenient. Fresh air ventilation available from opening door window, opening slot in front screen and fully opening front screen. Parallelogram wash wiper for upper screen ensuring good wiped area for maximum visibility. Wiper motor is fitted in the left hand side of the roof screen so as not to affect bucket visibility when loading. Optional lower screen wiper available. Fresh air ventilation and heater with windscreen demister. Infinitely variable blower speed, temperature and recirculation control with optional climate control. Fully adjustable deluxe suspension seat with arm rest adjustment and backrest recline. Optional radio with digital tuner fitted into the roof lining for maximum protection. Conveniently placed radio mute button incorporated into lower console. 12v power point and mobile phone holder built into the right hand console. Courtesy light can be operated from ground level and is illuminated for five minutes or until switched off improving operator access at night. Cab mounted roller blind protects operator from suns' glare through front or top screens.

### AMS – ADVANCED MANAGEMENT SYSTEM

Four selectable working modes link the operators control movements with the engine and hydraulic systems to maximise productivity and efficiency.

**A (Auto)** Up to 100% engine power and 100% flow. Gives variable power and speed depending on the operator's input, matching the demand for output and efficiency to the job. Power boost is automatically activated in this mode should hard conditions be encountered. Auto idle cuts in after a period of inactivity (between 5 and 30 seconds as set by the operator)

**E (Economy)** 80% engine power. 95% of hydraulic flow maximises economy while maintaining excellent output.

**P (Precision)** 55% engine power. 90% of hydraulic flow for fine control of grading operations.

**L (Lifting)** 55% engine power. 63% of hydraulic flow with permanent power boost for maximum lifting power and control.

The Auto mode allows the AMS processor to select the optimum operational performance to match the demands of the job while the three alternative modes give precise matching of application when specific tasks are undertaken.

The adjustable position monitor mounted on the front right hand pillar of the cab gives the operator a constant read out of mode, tracking range, operating temperature and a host of other information, while retaining excellent visibility of the monitor and the job being carried out.

The required flow for hammer applications can be set and stored in the AMS memory and is automatically activated whenever the hammer pedal is depressed.

A maintenance indicator warns of imminent service needs, and all servicing and basic checks can be carried out using only the in cab display.

### CONTROLS

**Excavator** All servo lever operated to ISO control pattern, independently adjustable to the seat.

**Tracks** Individually servo operated by foot pedal or hand lever. Speed selection via joystick button.

**Auxiliary** Via servo operated foot pedal.

**Control isolation** Via gate lock lever at cab entrance or panel switch.

**Engine speed** Dial type throttle control plus servo lever mounted one-touch idle control or separate selectable auto-idle with adjustable time delay using AMS.

**Engine stop** Ignition key operated and separate shut-down button.

**Horn** Operated via servo lever mounted button.

**Optional blade control** Independent lever in cab.



**SERVICE CAPACITIES**

	Litres	UK Gal
Fuel tank	253	55.6
Engine coolant	16.4	3.6
Engine oil	15	3.3
Swing reduction gear	2.2	0.5
Track reduction gear (each side)	3.0	0.7
Hydraulic system	124.0	27.3
Hydraulic tank	73.0	16.1

**WEIGHTS AND GROUND BEARING PRESSURES**

Machine equipped with 4.7m Monoboom, 2.5m Dipper, 417kg Excavating Bucket, operator and full fuel tank.

Shoe Width	Operating Weight	Bearing Pressure
500mm (20in.)	13844kg (30521lb)	0.44kg/sq. cm. (6.33lb/sq. in.)
600mm (24in.)	13951kg (30757lb)	0.37kg/sq. cm. (5.31lb/sq. in.)
700mm (28in.)	14059kg (30995lb)	0.32kg/sq. cm. (4.59lb/sq. in.)
850mm (33in.)	14221kg (31352lb)	0.27kg/sq. cm. (3.82lb/sq. in.)

**BUCKET AND ARM COMBINATION**

JCB Bucket	No Q/Hitch Fitted		Q/Hitch Fitted*	
	2.5m	3.0m	2.5m	3.0m
GP 500mm wide 0.235 cu.m (SAE heaped)	☐	☐	☐	☐
GP 600mm wide 0.315 cu.m (SAE heaped)	☐	☐	☐	☐
GP 700mm wide 0.39 cu.m (SAE heaped)	☐	☐	☐	☐
GP 750mm wide 0.43 cu.m (SAE heaped)	☐	☐	☐	☐
GP 800mm wide 0.47 cu.m (SAE heaped)	☐	☐	☐	☐
GP 900mm wide 0.55 cu.m (SAE heaped)	☐	☐	☐	☐
GP 1000mm wide 0.63 cu.m (SAE heaped)	☐	☐	☐	■
GP 1100mm wide 0.715 cu.m (SAE heaped)	☐	■	●	●
GP 1200mm wide 0.795 cu.m (SAE heaped)	■	■	●	●
GP 1300mm wide 0.88 cu.m (SAE heaped)	■	●	●	x

- ☐ = Suitable for General Excavating (Materials up to 2000kg/cu.m.)
- = Suitable for Light Excavating (Materials up to 1600kg/cu.m.)
- = Suitable for Grading & Loading Materials up to 1200kg/cu.m.
- X = Not Warranted

\* - BUCKET COMPATIBILITY USING JCB MECHANICAL Q/HITCH 980/89006 ONLY

**STANDARD / OPTIONAL EQUIPMENT**

**Standard Equipment:** Engine fan guard; Cold start pre-heat; Auto engine warm up; Double element air cleaner; Heavy duty alternator; Electrics isolator; Heavy duty batteries; Cab & engine soundproofing; Cab heater & screen demister; Tinted glass; Interior light; Coat hook; Cigarette lighter; Ashtray; Operator's storage shelf with cargo net; Removable floor mat; Windscreen wash/wipe; Plug-in power socket; Automatic power boost; Auto-idle; One-touch engine speed control; Hydraulic cushion control; Plexus hydraulic oil filtration; HSP pressure test points; Auxiliary pipework mounting brackets; Work lights – boom & mainframe mounted; Undercarriage belly guarding; Upper structure under covers; Swing system cover; External mirrors; Handrail & non slip walk ways; Quick connect engine oil drain pipe; Front screen blind; Quick connect fuel tank drain pipe; Hinged engine under cover.

**Optional Equipment:** Hose burst check valves & overload warning system; Tipping link mounted lift points; General purpose buckets; Ditch/grading buckets; Quickhitch buckets; Hydraulic hammers; Auxiliary pipework (full and low flow); Climate control; Cab mounted & rear work lights; Rotating beacon; Rain guard; Biodegradable oil; Air suspension seat with heated pad and lumbar support adjustment; Electric refuelling pump; Track guides; Lower screen wiper. Radio; Hot and cold climate hydraulic oils; Engine air intake filters; Widcore radiator; Leveling and stabilising blade; Various track plate widths; Additional cab mounted work lights; FOPS guard cab protection; Seat belt; Cab mesh screen guard; Fire extinguisher; Cab vandal cover kit; Travel alarm.

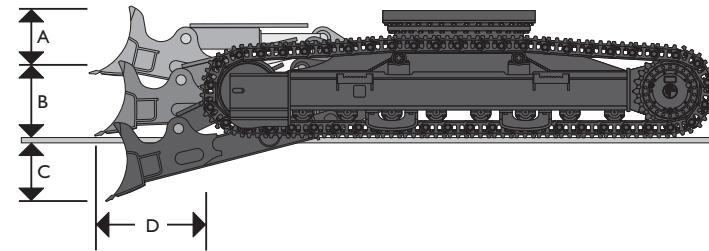
**OPTIONAL BLADE**

<b>A</b>	Blade height	mm (ft-in)	490 (1-7)
<b>B</b>	Blade lift above ground	mm (ft-in)	440 (1-5)
<b>C</b>	Blade cut below ground	mm (ft-in)	510 (1-8)
<b>D</b>	Blade forward of track	mm (ft-in)	440 (1-5)
	Dozer width – 500mm tracks	mm (ft-in)	2510 (8-3)
	Dozer width – 600mm tracks	mm (ft-in)	2610 (8-7)
	Dozer width – 700mm tracks	mm (ft-in)	2710 (8-11)
	<b>Dozer addition weight</b>		
	500mm tracks	kg (lb)	747 (1647)
	600mm tracks	kg (lb)	753 (1660)
	700mm tracks	kg (lb)	759 (1673)

## WORKING RANGE – JS145LC MONOBOOM

Boom length: 4.70m (15ft 5in)		
Dipper length:		2.50m (8ft 2in)
A	Maximum digging reach	mm (ft-in) 8340 (27-4)
B	Maximum digging reach (on ground)	mm (ft-in) 8197 (26-11)
C	Maximum digging depth	mm (ft-in) 5530 (18-2)
D	Maximum digging height	mm (ft-in) 9118 (29-11)
E	Maximum dumping height	mm (ft-in) 6729 (22-1)
F	Maximum vertical wall cut depth	mm (ft-in) 3625 (11-11)
G	Minimum swing radius	mm (ft-in) 2231 (7-4)
	Bucket rotation	182°
	Maximum dipper tearout (ISO 6015)	kgf (lbf) 6680 (14720)
	Maximum bucket tearout (ISO 6015)	kgf (lbf) 9375 (20667)
Dipper length:		3.00m (9ft 10in)
A	Maximum digging reach	mm (ft-in) 8796 (28-10)
B	Maximum digging reach (on ground)	mm (ft-in) 8660 (28-5)
C	Maximum digging depth	mm (ft-in) 6028 (19-9)
D	Maximum digging height	mm (ft-in) 9440 (30-11)
E	Maximum dumping height	mm (ft-in) 7041 (23-1)
F	Maximum vertical wall cut depth	mm (ft-in) 4050 (13-3)
G	Minimum swing radius	mm (ft-in) 2591 (8-6)
	Bucket rotation	182°
	Maximum dipper tearout (ISO 5016)	kgf (lbf) 5970 (13161)
	Maximum bucket tearout (ISO 5016)	kgf (lbf) 9375 (20667)

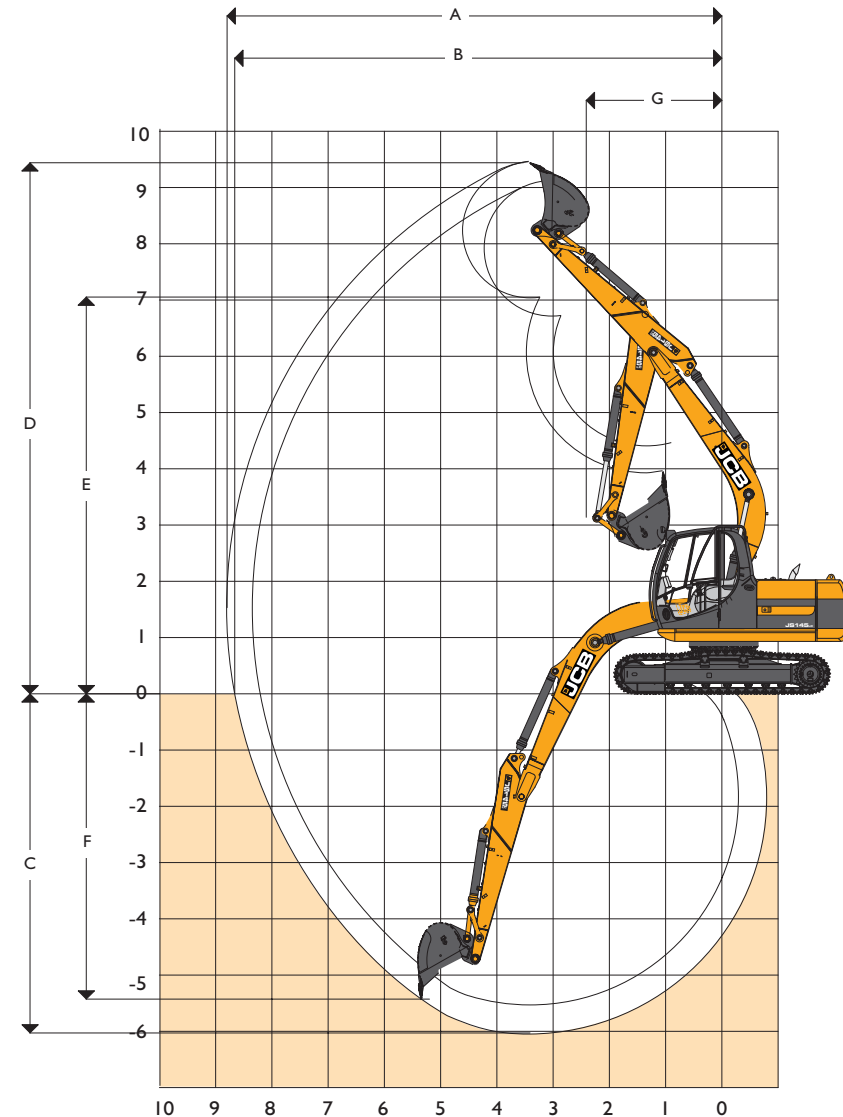

## WORKING RANGE – JS145LC T.A.B.

Boom length: 4.70m		
<b>Dipper length:</b>		<b>2.50m (8ft 2in)</b>
A	Maximum digging reach	mm (ft-in) 8751 (28-8)
B	Maximum digging reach (on ground)	mm (ft-in) 8614 (28-3)
C	Maximum digging depth	mm (ft-in) 5786 (18-12)
D	Maximum digging height	mm (ft-in) 9635 (31-7)
E	Maximum dumping height	mm (ft-in) 7229 (23-9)
F	Maximum vertical wall cut depth	mm (ft-in) 4140 (13-7)
G	Minimum swing radius	mm (ft-in) 2746 (9-0)
	Bucket rotation	182°
	Maximum Dipper tearout (ISO 6015)	kgf (lbf) 6680 (14720)
	Maximum Bucket tearout (ISO 6015)	kgf (lbf) 9375 (20667)
<b>Dipper length:</b>		<b>3.00m (9ft 10in)</b>
A	Maximum digging reach	mm (ft-in) 9226 (30-3)
B	Maximum digging reach (on ground)	mm (ft-in) 9096 (29-10)
C	Maximum digging depth	mm (ft-in) 6281 (20-7)
D	Maximum digging height	mm (ft-in) 10012 (32-10)
E	Maximum dumping height	mm (ft-in) 7606 (24-11)
F	Maximum vertical wall cut depth	mm (ft-in) 4580 (15-0)
G	Minimum swing radius	mm (ft-in) 3162 (10-5)
	Bucket rotation	182°
	Maximum Dipper tearout (ISO 6015)	kgf (lbf) 5970 (13161)
	Maximum Bucket tearout (ISO 6015)	kgf (lbf) 9375 (20667)

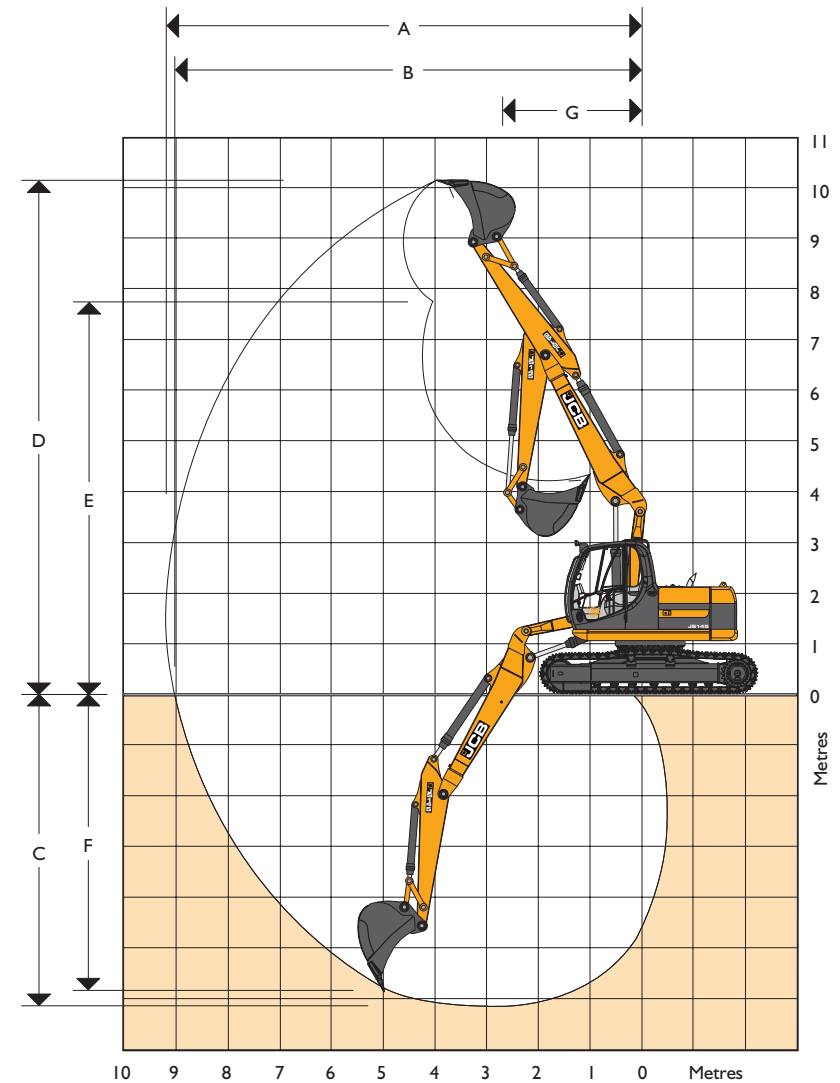



**LIFT CAPACITIES – Dipper Length: 2.50m, 5.0m Monoboom, Trackshoes: 700mm, No bucket.**
**JS145 LC MONO**

Reach	1.5m (4ft 11in)		3m (9ft 10in)		4.5m (14ft 9in)		6m (19ft 8in)		7.5m (24ft 7in)		Capacity at Max Reach			
Load Point Ht.	kg	kg	kg	kg	kg	kg	kg	kg	kg	kg	kg	kg	mm	
7.5m (24.7ft)												2960*	2960*	3815
6.0m (19.8ft)					2890*	2890*						2370*	2370*	5533
4.5m (14.9ft)					3150*	3150*	3100*	2730				2200*	2200*	6479
3.0m (9.10ft)			5390*	5390*	3910*	3910*	3360*	2660				2190*	2100	6982
1.5m (4.11ft)			7490*	6880	4830*	3830	3510	2560				2290*	1990	7136
0m			6830*	6610	5200	3670	3430	2480				2540*	2020	6967
- 1.5m (- 4.11ft)	5100*	5100*	8450*	6580	5130	3610	3400	2450				3060*	2240	6446
- 3.0m (- 9.10ft)	9270*	9270*	7430*	6680	5040*	3650						3840*	2820	5474
- 4.5m (- 14.9ft)														

**LIFT CAPACITIES – Dipper Length: 3.00m, 5.0m Monoboom, Trackshoes: 700mm, No bucket.**
**JS145 LC MONO**

Reach	1.5m (4ft 11in)		3m (9ft 10in)		4.5m (14ft 9in)		6m (19ft 8in)		7.5m (24ft 7in)		Capacity at Max Reach			
Load Point Ht.	kg	kg	kg	kg	kg	kg	kg	kg	kg	kg	kg	kg	mm	
7.5m (24.7ft)					2860*	2860*						2580*	2580*	4622
6.0m (19.8ft)					2410*	2410*	2510*	2510*				2170*	2170*	6113
4.5m (14.9ft)					2700*	2700*	2750*	2750*				2040*	2040*	6980
3.0m (9.10ft)			4450*	4450*	3480*	3480*	3070*	2670				2040*	1890	7448
1.5m (4.11ft)			6980*	6980*	4460*	3860	3510	2550	2520	1830		2130*	1800	7593
0m			7510*	6590	5190	3650	3400	2450				2340*	1820	7434
- 1.5m (- 4.11ft)	4580*	4580*	8530*	6480	5080	3550	3350	2400				2740	1980	6949
- 3.0m (- 9.10ft)	7870*	7870*	7850*	6540	5080	3560	3380	2430				3340	2400	6060
- 4.5m (- 14.9ft)			5970*	5970*	3720*	3710						3670*	3670*	4528



Lift capacity front and rear.



Lift capacity full circle.

- Notes:**
1. For lifting capacity including bucket, subtract total weight of bucket or bucket and quickhitch from above values.
  2. Lifting capacities are based on ISO 10567, that is: 75% of minimum tipping load or 87% of hydraulic lift capacity, whichever is the less. Lifting capacities marked\* are based on hydraulic capacity.
  3. Lift capacities assume that the machine is on firm, level ground.
  4. Lift capacities may be limited by local regulations. Please refer to your dealer.

## LIFT CAPACITIES – Dipper Length: 2.50m, 5.0m T.A.B., Trackshoes: 500mm, No bucket.

## JS145 LC T.A.B.

Reach	1.5m (4ft 11in)		3m (9ft 10in)		4.5m (14ft 9in)		6m (19ft 8in)		7.5m (24ft 7in)		Capacity at Max Reach		
													mm
Load Point Ht.	kg	kg	kg	kg	kg	kg	kg	kg	kg	kg	kg	kg	mm
7.5m (24.7ft)					3300*	3300*					3040*	3040*	4558
6.0m (19.8ft)					2850*	2850*	2860*	2590			2460*	2460*	6065
4.5m (14.9ft)					3190*	3190*	2960*	2590			2250*	2010	6938
3.0m (9.10ft)					3940*	3830	3250*	2490			2190*	1780	7409
1.5m (4.11ft)					4780*	3550	3300	2370	2370	1710	2230*	1690	7555
0m			3700*	3700*	4860	3380	3210	2280			2390*	1720	7395
- 1.5m (- 4.11ft)			7150*	6110	4800	3320	3170	2250			2640	1890	6907
- 3.0m (- 9.10ft)			7020*	6240	4860	3380	3250*	2330			3220*	2330	6012

## LIFT CAPACITIES – Dipper Length: 3.00m, 5.0m T.A.B., Trackshoes: 500mm, No bucket.

## JS145 LC T.A.B.

Reach	1.5m (4ft 11in)		3m (9ft 10in)		4.5m (14ft 9in)		6m (19ft 8in)		7.5m (24ft 7in)		Capacity at Max Reach		
													mm
Load Point Ht.	kg	kg	kg	kg	kg	kg	kg	kg	kg	kg	kg	kg	mm
7.5m (24.7ft)					2640*	2640*					2640*	2640*	5315
6.0m (19.8ft)					2440*	2440*	2590*	2590*			2230*	2160	6650
4.5m (14.9ft)					2800*	2800*	2670*	2600			2080*	1760	7453
3.0m (9.10ft)					3550*	3550*	3000*	2480	2390	1730	2030*	1570	7893
1.5m (4.11ft)					4440*	3540	3270	2340	2330	1670	2080*	1500	8030
0m					4790	3320	3150	2230	2290	1630	2130	1520	7880
- 1.5m (- 4.11ft)	3060*	3060*	6650*	5910	4690	3220	3090	2170			2320	1650	7425
- 3.0m (- 9.10ft)			7430*	6010	4710	3240	3110	2200			2760	1970	6601

Lift capacity front and rear.

Lift capacity full circle.

- Notes:**
1. For lifting capacity including bucket, subtract total weight of bucket or bucket and quickhitch from above values.
  2. Lifting capacities are based on ISO 10567, that is: 75% of minimum tipping load or 87% of hydraulic lift capacity, whichever is the less. Lifting capacities marked\* are based on hydraulic capacity.
  3. Lift capacities assume that the machine is on firm, level ground.
  4. Lift capacities may be limited by local regulations. Please refer to your dealer.

**LIFT CAPACITIES – Dipper Length: 2.50m, 4.70m Monoboom, Trackshoes: 700mm, No bucket, Dozer.**
**JS145 LC MONO**

Reach	1.5m (4ft 11in)		3m (9ft 10in)		4.5m (14ft 9in)		6m (19ft 8in)		7.5m (24ft 7in)		Capacity at Max Reach			
Load Point Ht.	kg	kg	kg	kg	kg	kg	kg	kg	kg	kg	kg	kg	mm	
7.5m (24.7ft)												2960*	2960*	3815
6.0m (19.8ft)					2890*	2890*						2370*	2370*	5533
4.5m (14.9ft)					3150*	3150*	3100*	2850				2200*	2200*	6479
3.0m (9.10ft)			5390*	5390*	3910*	3910*	3360*	2780				2190*	2190*	6982
1.5m (4.11ft)			7490*	7200	4830*	4010	3750	2680				2290*	2090	7136
0m			6830*	6830*	5470*	3850	3660	2600				2540*	2130	6967
- 1.5m (- 4.11ft)	5100*	5100*	8450*	6900	5480	3790	3630	2580				3060*	2350	6446
- 3.0m (- 9.10ft)	9270*	9270*	7430*	7000	5040*	3830						3840*	2960	5474
- 4.5m (- 14.9ft)														

**LIFT CAPACITIES – Dipper Length: 3.00m, 4.70m Monoboom, Trackshoes: 700mm, No bucket, Dozer.**
**JS145 LC MONO**

Reach	1.5m (4ft 11in)		3m (9ft 10in)		4.5m (14ft 9in)		6m (19ft 8in)		7.5m (24ft 7in)		Capacity at Max Reach			
Load Point Ht.	kg	kg	kg	kg	kg	kg	kg	kg	kg	kg	kg	kg	mm	
7.5m (24.7ft)					2860*	2860*						2580*	2580*	4622
6.0m (19.8ft)					2410*	2410*	2510*	2510*				2170*	2170*	6113
4.5m (14.9ft)					2700*	2700*	2750*	2750*				2040*	2040*	6980
3.0m (9.10ft)			4450*	4450*	3480*	3480*	3070*	2790				2040*	1990	7448
1.5m (4.11ft)			6980*	6980*	4460*	4040	3520*	2680	2580*	1930		2130*	1890	7593
0m			7510*	6910*	5230*	3830	3640*	2580				2340*	1910	7434
- 1.5m (- 4.11ft)	4580*	4580*	8530*	6800	5420	5730	3580	2530				2760*	2080	6949
- 3.0m (- 9.10ft)	7870*	7870*	7850*	6860	5260*	3740	3610	2550				3570	2520	6060
- 4.5m (- 14.9ft)			5970*	5970*	3720*	3720*						3670*	3670*	4528



Lift capacity front and rear.



Lift capacity full circle.

- Notes:**
1. For lifting capacity including bucket, subtract total weight of bucket or bucket and quickhitch from above values.
  2. Lifting capacities are based on ISO 10567, that is: 75% of minimum tipping load or 87% of hydraulic lift capacity, whichever is the less. Lifting capacities marked\* are based on hydraulic capacity.
  3. Lift capacities assume that the machine is on firm, level ground.
  4. Lift capacities may be limited by local regulations. Please refer to your dealer.



## A GLOBAL COMMITMENT TO QUALITY

JCB's total commitment to its products and customers has helped it grow from a one-man business into Britain's largest privately owned manufacturer of backhoe loaders, crawler excavators, wheeled excavators, telescopic handlers, wheeled loaders, dump trucks, rough terrain fork lifts, industrial fork lifts, mini/midi excavators, skid steer loaders, tractors and compaction equipment.

By making constant and massive investments in the latest production technology, the JCB factories have become some of the most advanced in the world.

By leading the field in innovative research and design, extensive testing and stringent quality control, JCB machines have become renowned all over the world for performance, value and reliability.

And with a global sales and service network of more than 650 dealers and agents, we aim to deliver the best customer support in the industry.

Through setting the standards by which others are judged, JCB has become one of the world's most impressive success stories.

